



## DECENTRALISED HEAT RECOVERY UNIT

### APPLICATION

Decentralised dual flow heat recovery unit, suitable for wall installation in premises such as offices, waiting rooms and school rooms, up to 75m<sup>2</sup>.

### SPECIFICATION

**Outer fan casing** manufactured from high quality ABS providing long lasting and robust construction. The unit is finished in white RAL 9010.

**Internal structure** manufactured from expanded polypropylene providing reduced sound emissions and maximised air tightness and thermal insulation.

**EC external rotor motors** fitted as standard for energy saving. Provided with integral thermal protection, mounted on sealed for life ball bearings.

Backward curved **centrifugal impeller** dynamically balanced and directly driven by the motor to provide a smooth airflow through the unit.

Highly efficient counterflow **heat exchanger** to maximise thermal recovery.

### FEATURES & BENEFITS

**Ease of installation & money saving:** no need to plan/install any complicated ducting system.

**Silent operation** thanks to the fact that the brushless motors are inside the EPP (expanded polypropylene) structure which attenuates the sound.

**ISO Coarse 60% filter (G4)** easy removable for cleaning, supplied as standard. ISO ePM1 60% filter (F7) on request.

**Automatic anti-frost protection** to prevent frost building up on the exhaust side of the heat exchanger.

**Two drainage holes** to meet climate requirement.

**Tested to the latest standards:** units are tested in the TÜV Rheinland recognised laboratory at Aerauliqa, meaning accurate, up to date information on electrical safety, performance and noise level that can be relied upon. Designed and manufactured in accordance with EN60335-2-80 (Low Voltage Directive) and the EMC Directive (Electromagnetic Compatibility).

### OPERATION

- One speed.
- Two speed.
- Variable speed with remote control CTRL-M.
- Variable speed with remote home automation system (BMS) or ballast potentiometer.
- 3 speed and free cooling option via remote controller CTRL-S.

## Example of a complete ventilation system

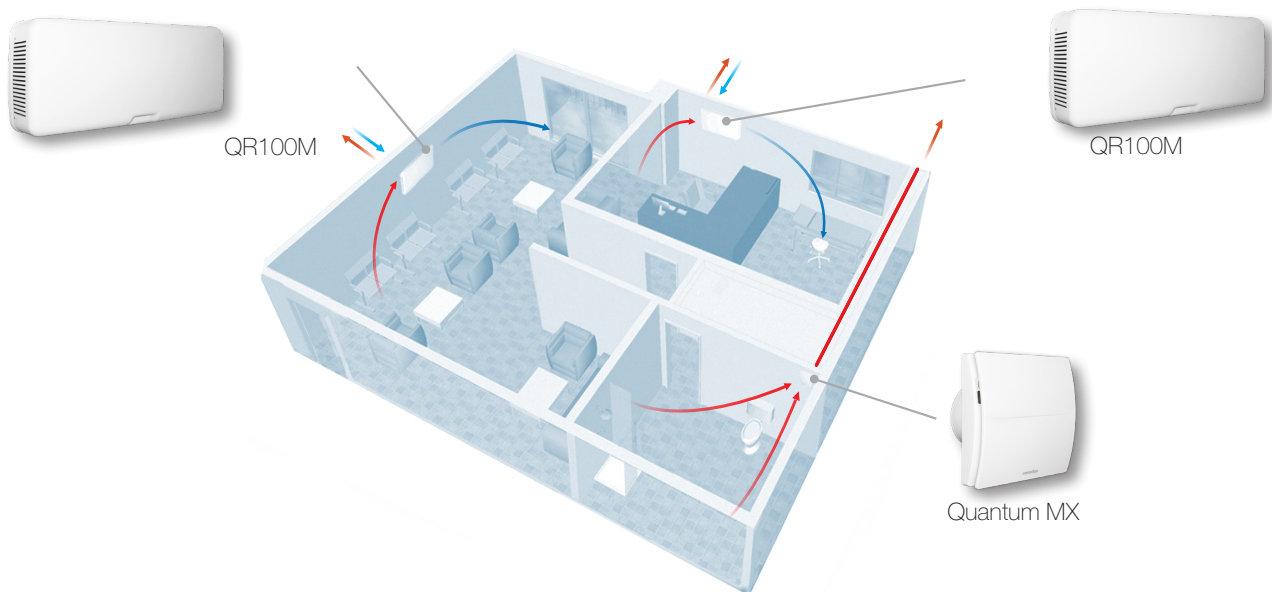

**Application:** new build/renovation.

**How it works:** a continuous running decentralised heat recovery unit (QR100) transfers thermal energy from air extracted from indoor rooms to incoming fresh air, with top acoustic comfort.

The system can also include a single flow decentralised unit (Quantum MX) mounted in the wet room. No air distribution system is needed.

**Energy saving:** the preheated/precooled fresh air and continuous air changes reduce the demand for additional heating/air-conditioning. The EC brushless motors significantly reduce the electricity consumption.

**Indoor Air Quality:** a correctly specified mechanical ventilation system can ensure the quality of the indoor air is constantly maintained for the health and well-being of the occupants as well as of the building.

Duly maintained filters of the QR100 ensure that incoming air is suitably filtered of dust and pollen before it enters the home.

## Dimensions (mm) and Weight (kg)

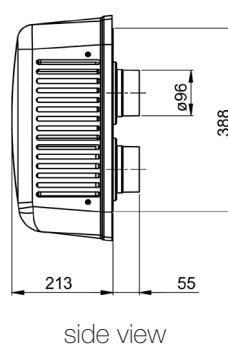
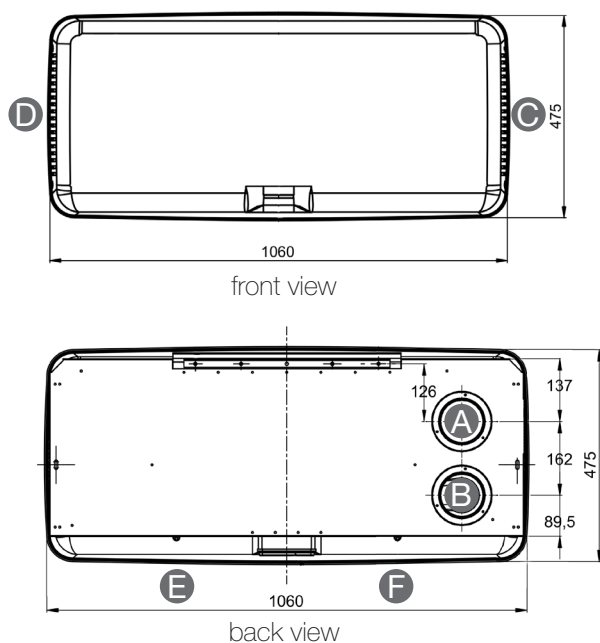

Model	QR100M
Weight	12,5
A	Intake air from outside
B	Exhaust air to outside
C	Supply air to inside
D	Extract air from inside
E	Winter condensation drainage
F	Summer condensation drainage

# QR100M

## Product fiche - ErP Directive, Regulations 1253/2014 - 1254/2014

a)	Mark	-	AERAULIQA	
b)	Model	-	QR100M	
c)	SEC class	-	A	B
c1)	SEC warm climates	kWh/m <sup>2</sup> .a	-13,3	-2,4
c2)	SEC average climates	kWh/m <sup>2</sup> .a	-38,1	-26,3
c3)	SEC cold climates	kWh/m <sup>2</sup> .a	-76,8	-63,4
	Energy label	-	Yes	
d)	Unit typology	-	Residential - bidirectional	
e)	Type of drive	-	Variable speed drive	
f)	Type of Heat Recovery System	-	Heat recovery	
g)	Thermal efficiency of heat recovery	%	87	
h)	Maximum flow rate @ 0 Pa	m <sup>3</sup> /h	97	
i)	Electric power input (alla Maximum flow rate)	W	58	
j)	Sound power level (L <sub>WA</sub> )	dBA	56	
k)	Reference flow rate	m <sup>3</sup> /h	68	
l)	Reference pressure difference	Pa	10	
m)	Specific power input (SPI)	W/m <sup>3</sup> /h	0,515	
n1)	Control factor	-	0,65	1
n2)	Control typology	-	Local demand control	Manual control (no DCV)
o1)	Maximum internal leakage rate	%	1	
o2)	Maximum external leakage rate	%	1	
p1)	Internal mixing rate	%	1	
p2)	External mixing rate	%	2	
q)	Visual filter warning	-	Absent	
r)	Instructions to install regulated grilles	-	N/A	
s)	Internet address for pre/disassembly instructions	-	www.aerauliqa.com	
t)	Airflow sensitivity to pressure variations	%	5	
u)	Indoor/outdoor air tightness	m <sup>3</sup> /h	20	
v1)	AEC - Annual electricity consumption - warm climates	kWh	3	7,1
v2)	AEC - Annual electricity consumption - average climates	kWh	3,4	7,5
v3)	AEC - Annual electricity consumption - cold climates	kWh	8,8	12,9
w1)	AHS - Annual heating saved - warm climates	kWh	20,8	20,1
w2)	AHS - Annual heating saved - average climates	kWh	46	44,4
w3)	AHS - Annual heating saved - cold climates	kWh	90,1	87
	Sound pressure @ 3m <sup>(1)</sup>	dB(A)	29	
	Ambient temperature max	°C	+40	
	Degree of protection IP	-	X4	
	Marking	-	CE	

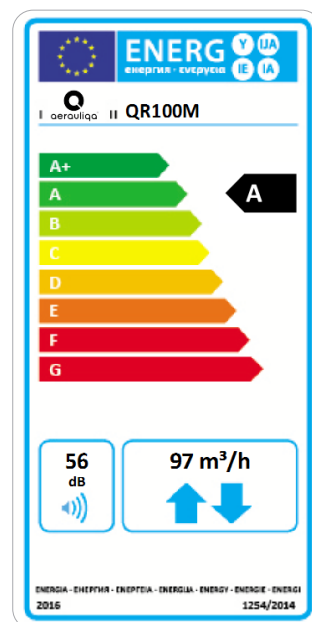

- 220-240V ~ 50/60Hz.

- air performance measured according to ISO 5801 a 230V 50Hz, air density 1,2Kg/m<sup>3</sup>.

- data measured in the TÜV Rheinland recognised laboratory in Aerauliqa.

(1) sound pressure level @ 3m in free field, breakout, speed 40%, for comparative purposes only.

## Performance curve

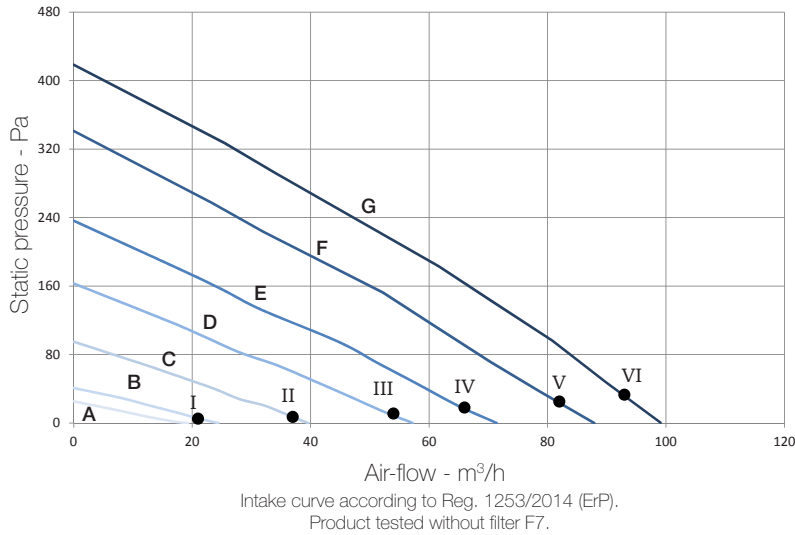

Curve	Speed %	W max	m³/h max
A (min)	24	8	19
B	30	9	24
C	43	13	40
D	61	22	57
E	75	34	71
F	93	51	88
G (max)	100	58	97

Working point	W	m³/h	SPI (W/m³/h)	$\eta_t$ % <sup>(1)</sup>
I	8,3	21	0,395	93
II	13,0	37	0,351	91
III	21,8	54	0,404	89
IV	33,1	66	0,5015	87
V	50,2	82	0,6122	85
VI	57,5	93	0,6183	84

(1) Termal efficiency of the unit.

## Details

