



2025



CENTRALIZED HEAT RECOVERY UNIT COMPACT SIZE AND SILENT

APPLICATION

Whole-house heat recovery unit, suitable for vertical installation. Can be installed in cupboard or narrow spaces thanks to its compact sizes.

SPECIFICATION

Outer fan casing manufactured from powder coated galvanised sheet steel providing long lasting and robust construction. The unit is finished in white RAL 9010.

Internal structure manufactured from EPP (expanded polypropylene) providing reduced sound emissions and maximised air tightness and thermal insulation.

EC external rotor motors fitted as standard for energy saving. Provided with integral thermal protection, mounted on sealed for life ball bearings.

Backward curved centrifugal impeller dynamically balanced and directly driven by the motor to provide a smooth airflow through the unit.

Highly efficient **counterflow heat exchanger** to maximise thermal recovery.

FEATURES AND BENEFITS

Ease of installation: fixing brackets supplied to hang the unit easily on the wall.

Simplified electric wiring: the unit is supplied pre-cabled.

Removable front panel for quick access to filters and heat exchanger.

ISO ePM10 50% (M5) filters easy removable for cleaning. **ISO ePM1 55% (F7) filter** on request.

Integral automatic bypass for free cooling during the summer season.

Automatic anti-frost protection to prevent frost building up on the exhaust side of the heat exchanger.

Two drainage holes to meet climate requirement.

Left/right configuration of the unit for mounting flexibility.

Tested to the latest standards: units are tested in the TÜV Rheinland accredited internal laboratory according to the operating document IEC OD 2048 (level CTF1) for the IEC 60335-1 and IEC 60335-2-80 Standards, meaning accurate, up to date information on electrical safety, performance and noise level that can be relied upon.

Designed and manufactured in accordance with EN60335-2-80 (Low Voltage Directive) and the EMC Directive (Electromagnetic Compatibility).

OPERATION

The unit is supplied with a multi-function LCD display (CTRL-DSP) for automatic control and convenience, providing:

- 3 speed settings (adjustable).
- Boost option.
- Holiday mode.
- Night mode.
- Weekly timer.
- Bypass setting.
- Airflow balancing.
- Filter replacement and fan failure indicator.
- Working hour counter.
- Setting saving and loading.
- Suitable for remote ambient sensors (SEN-HY, SEN-PIR).
- ModBus interface.
- Connection to remote pre/post heating element.
- Connection to remote water coil for heating.
- Left or Right hand configuration (air connection).

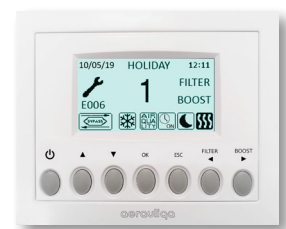

CTRL-DSP
(supplied as standard)

QR280A

Example of a complete ventilation system

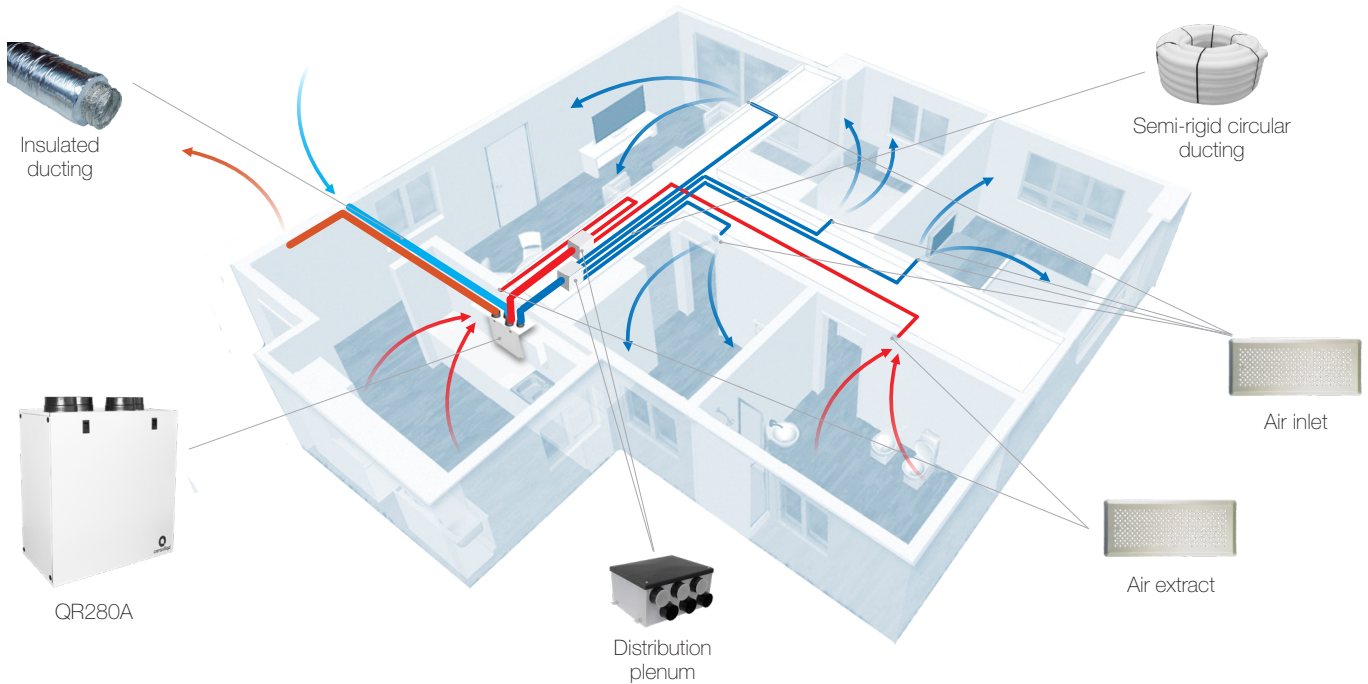

How it works: a continuous running heat recovery unit (QR280A) transfers heat from humid air extracted from wet rooms to warm incoming fresh air which is ducted to habitable rooms. Thanks to the easy-to-fit air distribution system each single ambient can be properly ventilate: the boost function enables rapid extract of increased moisture or pollutant levels. It also provides discrete installation and very quite operation.

Energy saving: the preheated/precooled fresh air and continuous air changes reduce the demand for additional heating/air-conditioning. The EC brushless motors significantly reduce the electricity consumption.

Indoor Air Quality: a correctly specified mechanical ventilation system can ensure the quality of the indoor air is constantly maintained for the health and well-being of the occupants as well as of the building. Duly maintained filters ensure that incoming air is suitably filtered of dust and pollen before it enters the home.

Dimensions (mm) and Weight (kg)

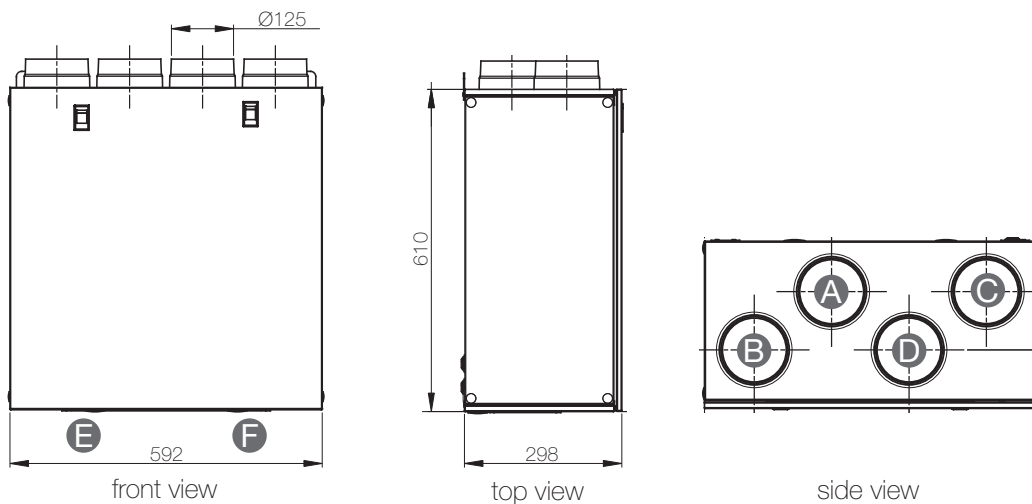

Model	QR280A
Weight	21,4
A	Intake air from outside
B	Exhaust air to outside
C	Supply air to inside
D	Extract air from inside
E	Winter condensation drainage
F	Summer condensation drainage

LEFT orientation

Product fiche - ErP Directive, Regulations 1253/2014 - 1254/2014

a)	Mark	-	AERAULIQA		
b)	Model	-	QR280A		
c)	SEC class	-	A	A	B
c1)	SEC warm climates	kWh/m ² .a	-15,9	-12,0	-8,4
c2)	SEC average climates	kWh/m ² .a	-40,6	-36,2	-32,3
c3)	SEC cold climates	kWh/m ² .a	-79,2	-73,9	-69,3
	Energy label	-	Yes		
d)	Unit typology	-	Residential - bidirectional		
e)	Type of drive	-	Variable speed drive		
f)	Type of Heat Recovery System	-	Heat recovery		
g)	Thermal efficiency of heat recovery	%	85		
h)	Maximum flow rate @ 100 Pa	m ³ /h	270		
i)	Electric power input (maximum flow rate)	W	170		
j)	Sound power level (L _{WA})	dBA	57		
k)	Reference flow rate	m ³ /h	189		
l)	Reference pressure difference	Pa	50		
m)	Specific power input (SPI)	W/m ³ /h	0,370		
n1)	Control factor	-	0,65	0,85	1,0
n2)	Control typology	-	Local demand control	Central demand control	Manual control (no DCV)
o1)	Maximum internal leakage rate	%	2,9		
o2)	Maximum external leakage rate	%	1,3		
p1)	Internal mixing rate	%	N/A		
p2)	External mixing rate	%	N/A		
q)	Visual filter warning	-	Visual filter warning on display		
r)	Instructions to install regulated grilles	-	N/A		
s)	Internet address for pre/disassembly instructions	-	www.aerauliqa.com		
t)	Airflow sensitivity to pressure variations	%	N/A		
u)	Indoor/outdoor air tightness	m ³ /h	N/A		
v1)	AEC - Annual electricity consumption - warm climates	kWh	2,0	3,4	4,6
v2)	AEC - Annual electricity consumption - average climates	kWh	2,4	3,8	5,1
v3)	AEC - Annual electricity consumption - cold climates	kWh	7,8	9,2	10,5
w1)	AHS - Annual heating saved - warm climates	kWh	20,8	20,4	20,0
w2)	AHS - Annual heating saved - average climates	kWh	46,0	45,0	44,3
w3)	AHS - Annual heating saved - cold climates	kWh	89,9	88,1	86,7
	Sound pressure @ 3m ⁽¹⁾	dB(A)	24		
	Ambient temperature max	°C	+40		
	Degree of protection IP	-	X2		
	Marking/Mark	-	CE		

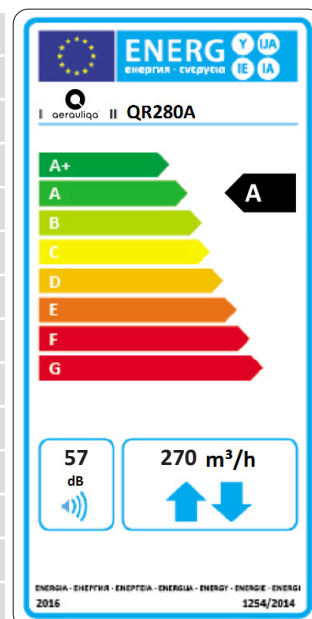

- 220-240V ~ 50/60Hz

- air performance according to ISO 5801 a 230V 50Hz, air density 1,2 Kg/m³.

- data according to the test report issued by the independent laboratory IMQ S.p.a.

- thermal performances according to EN 13141-7

- sound levels according to EN ISO 3741

(1) sound pressure level @ 3m in free field, breakout, speed 50%, for comparative purposes only.

QR280A

Performance curve

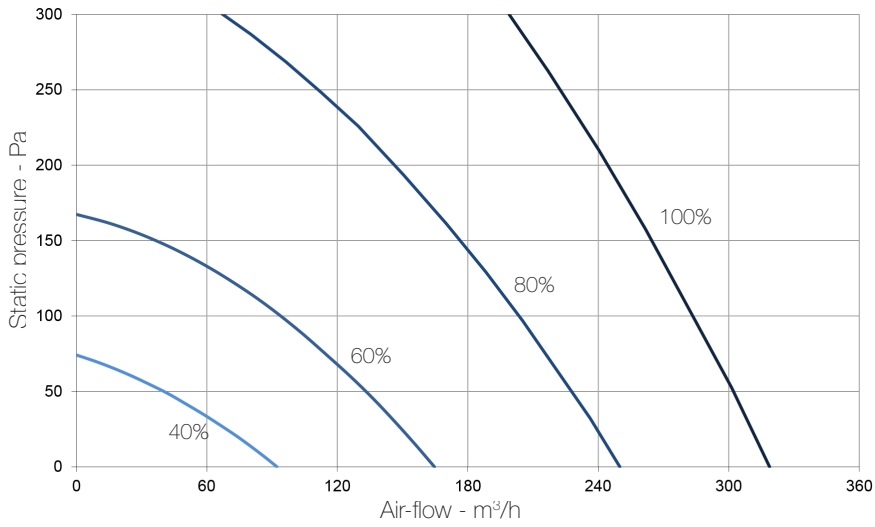

Intake curve according to Reg.1253/2014 (ErP).

Speed %	W max	m³/h max
40	14	92
60	33	165
80	86	250
100	178	319

Sound level

	Speed 100%	Lw dB - SOUND POWER OCTAVE BAND							Lp dB(A)	
		125	250	500	1 K	2 K	4 K	8K	Tot	@3m
Intake		53	56	58	54	47	36	29	62	38
Supply		56	62	70	70	63	55	50	74	43
Extract		55	57	59	53	49	34	29	63	38
Exhaust		59	64	76	72	65	57	51	78	55
Breakout		55	59	60	61	60	51	37	67	45

	Speed 80%	Lw dB - SOUND POWER OCTAVE BAND							Lp dB(A)	
		125	250	500	1 K	2 K	4 K	8K	Tot	@3m
Intake		51	54	50	50	43	29	27	58	33
Supply		55	66	61	62	59	47	42	69	46
Extract		53	58	50	50	42	27	26	60	34
Exhaust		56	75	63	64	61	49	44	76	51
Breakout		53	58	53	53	54	44	31	62	38

	Speed 60%	Lw dB - SOUND POWER OCTAVE BAND							Lp dB(A)	
		125	250	500	1 K	2 K	4 K	8K	Tot	@3m
Intake		43	46	42	42	35	21	19	50	25
Supply		47	58	53	54	51	39	34	61	38
Extract		45	50	42	43	34	20	18	52	26
Exhaust		48	68	55	56	53	41	36	68	43
Breakout		46	51	45	46	46	36	23	54	30

	Speed 40%	Lw dB - SOUND POWER OCTAVE BAND							Lp dB(A)	
		125	250	500	1 K	2 K	4 K	8K	Tot	@3m
Intake		38	44	36	30	22	13	18	45	17
Supply		43	47	48	42	36	24	21	52	27
Extract		39	44	37	28	22	13	18	46	17
Exhaust		44	47	49	44	37	25	20	52	28
Breakout		39	43	38	35	32	21	20	46	20

Lp dB(A) @3m for comparative purposes only.