



CENTRIFUGAL BUILT-IN EXTRACT FAN

APPLICATION

Top silent centrifugal extract fan suitable to extract stale air from small and medium size environments such as toilets and bathrooms in homes, hotels and offices. Conceived to overcome the resistance of long ducting system, they are suitable for built-in mounting on wall or ceiling and for simultaneous extraction of odours and vapors from the ambient and additionally from the toilet bowl or adjacent rooms.

SPECIFICATION

Casing made of high-quality ABS and polystyrene provides long lasting shockproof and robust construction. The unit is finished in white RAL 9010 and are UV resistant.

Forward curved centrifugal impeller, providing enhanced aerodynamic properties, low noise and increased efficiency.

Two-speed induction motor totally enclosed type, with integral thermal protection, mounted on sealed for life high quality ball bearings (30.000h), ideal for cool climate. Suitable for continuous and intermittent running.

Internal filter made from acrylic polyester.

FEATURES & BENEFITS

IPX5 protection degree.

Aesthetic front flat cover for modern interior design easily removed for cleaning.

Versatile casing, with the Ø75mm outlet which can be positioned upwards, downwards, to the right or left.

Additional side inlet Ø50mm (supplied as standard) for secondary air-extraction from adjacent rooms or from the toilet bowl, in combination with the standard extraction point through the design front cover.

Plaster board built-in fixing through dedicated kit (accessory on request).

Internal filter to protect the impeller and the motor. Easy to be removed for cleaning.

Discharge air-tight shutter, compliant with DIN 18017-3, to prevent the return of odors or cold external currents when the unit is off. It allows to have multiple units discharging into the same main duct without contaminating the flows coming from different apartments (e.g. in multi-level structures).

Integral **sound-proof foam** for acoustic comfort.

Improved performance thanks to the unique air straightener to optimise performance and reduce power consumption.

Totally recyclable plastic components, environmentally friendly.

Double insulated: no earth connection is required.

Tested to the latest standards: units are tested in the TÜV Rheinland recognised laboratory at Aerauliqa, meaning accurate, up to date information on electrical safety, performance and noise level that can be relied upon. Designed and manufactured in accordance with EN60335-2-80 (Low Voltage Directive) and the EMC Directive (Electromagnetic Compatibility).

VERSIONS

Standard

The fan is operated via a dedicated ON/OFF switch or the light switch.

Run-on timer

The fan is equipped with a timer circuit adjustable from ± 1' to 25'. Operation: after switching off, the fan continues to run for the pre-set period of time.

Humidistat & Timer

The fan is provided with an electronic circuit having a humidity sensor on board (adjustable from 50% to 95% RH) and a timer, adjustable from ± 1' to 25'. Operation: when the percentage of relative humidity is higher/lower than the pre-set threshold, the fan is automatically activated/deactivated. After switching off, the fan continues to run for the pre-set period of time.

Silent Running

The above versions are also available in a silent running configuration for top acoustic comfort.

Dimensions (mm) and Weight (kg)

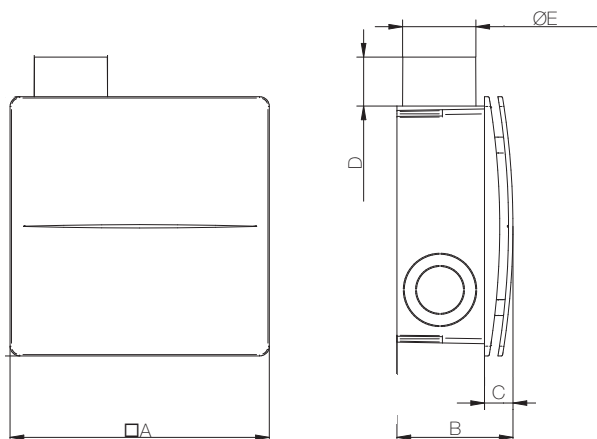

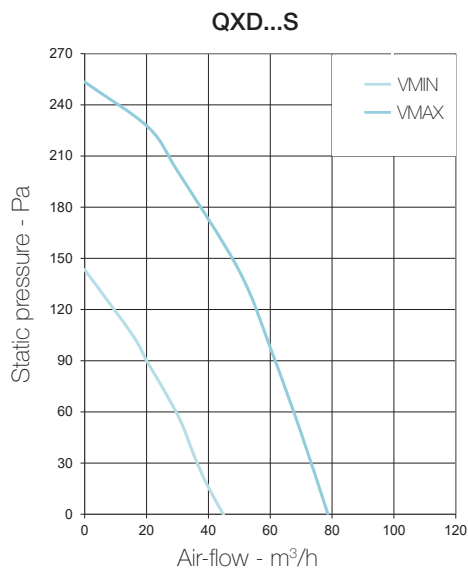
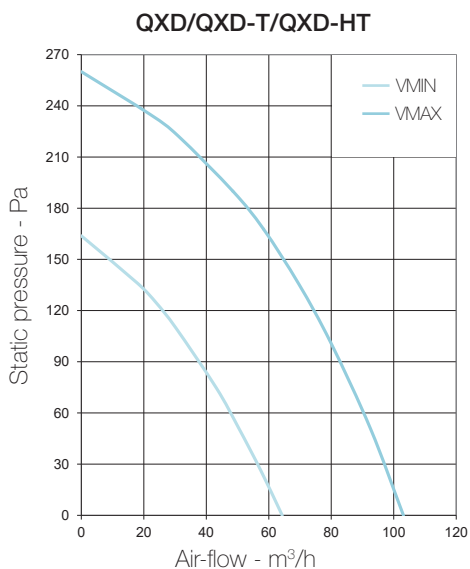

Model	QXD
□A	265
B	119
C	29
D	50
ØE	75
Weight	2,25

Performance curve



Performances

Model	QXD	QXD...S
Air-flow m ³ /h max	103/64	79/45
Static pressure Pa max	260/164	253/143
Power consumption W max	29/19	27/21
Sound pressure dB(A) @ 3m ⁽¹⁾	30/22	23/15
Ambient temperature °C max	50	50
Marking	CE 	CE 

- 220-240V ~ 50/60Hz.
- air performance measured according to ISO 5801 a 230V 50Hz, air density 1,2 Kg/m³.
- (1) sound pressure level @ 3m in free field, for comparative purposes only.



Type Approved
Safety
Regular Production
Surveillance

www.tuv.com
ID 0217007721

Examples of installation

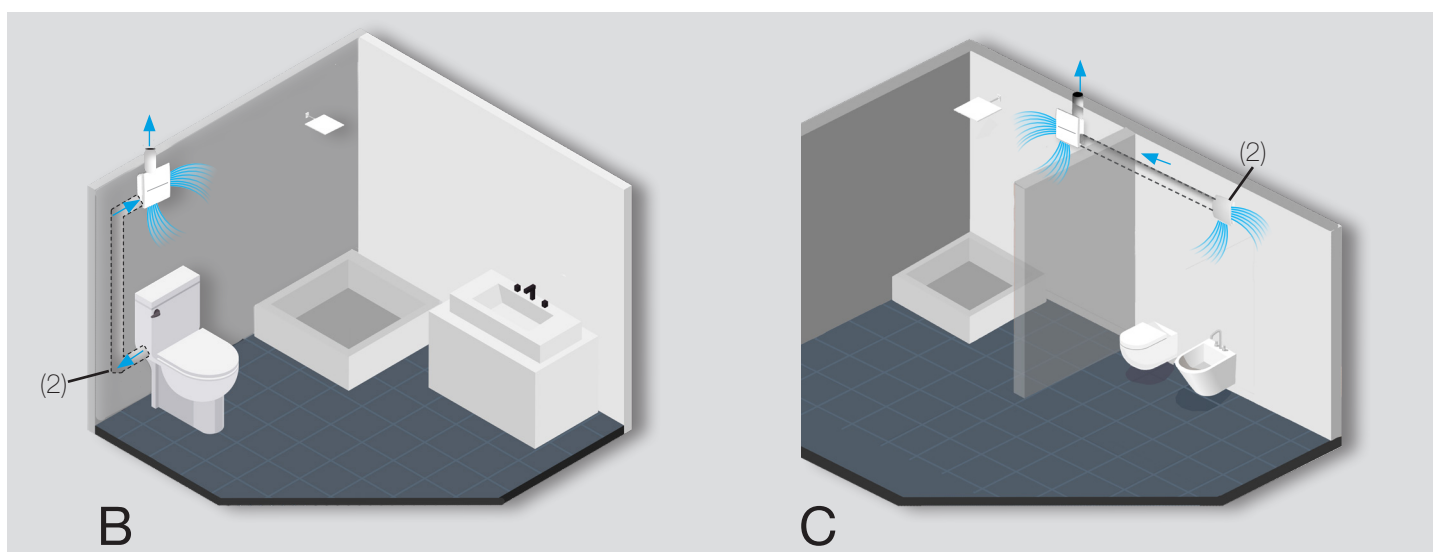
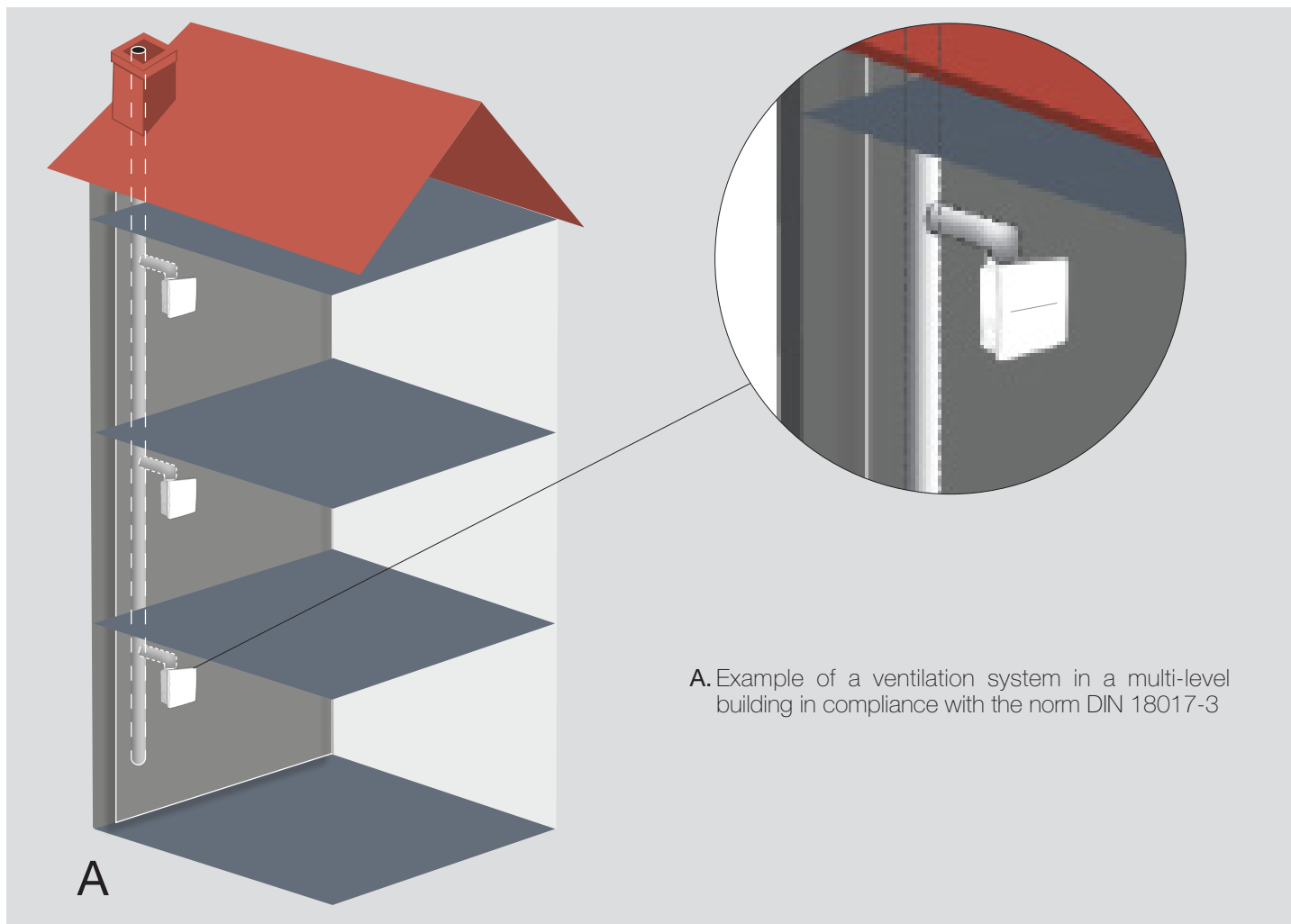

Details of the unit

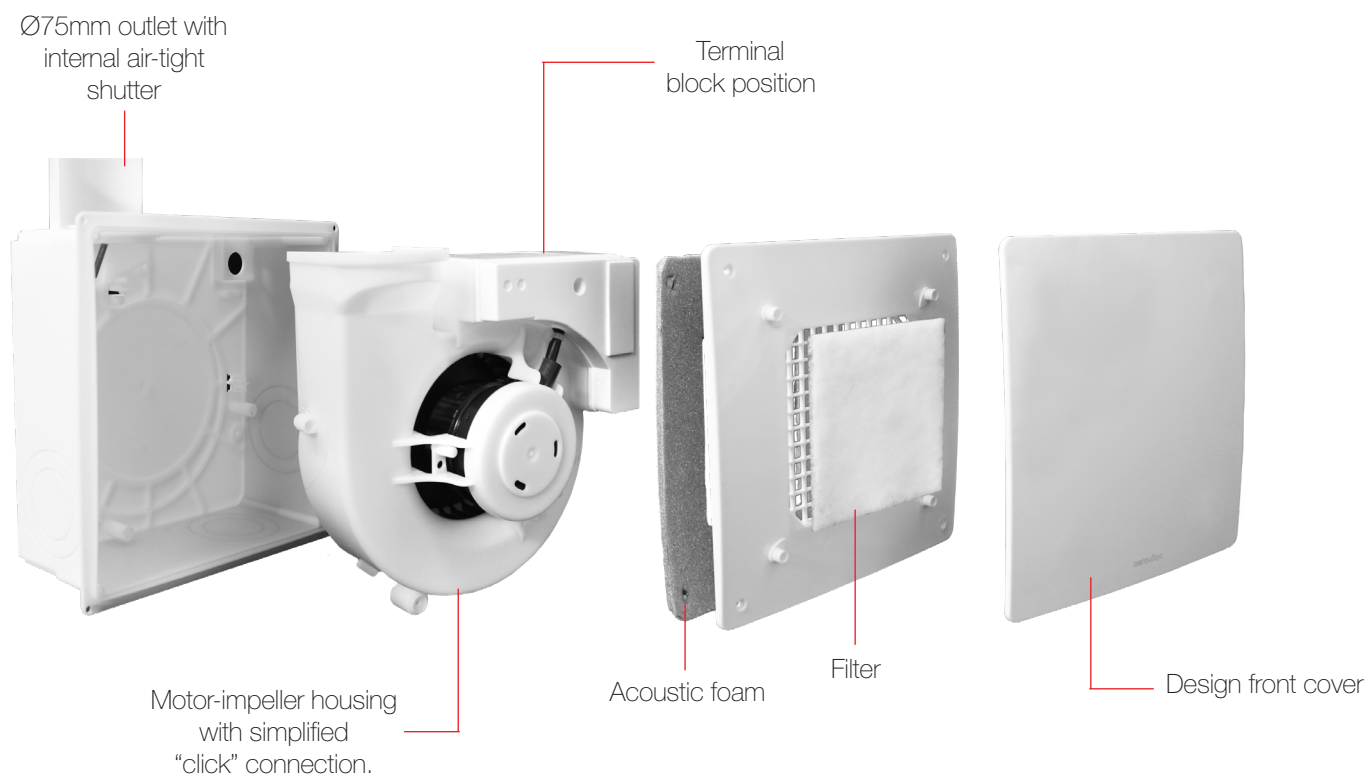

Details of the casing

